

E.E. / BAC Lightning F.53 (F6 mk.53) Kuwait Air Force

For 1/32: recommended kit Trumpeter F2A / F6 #02281 (or even better: the rare Echelon Lightning vacuform kit).

HISTORY

From end 1968 Kuwait acquired for its air force E.E. Lightnings. These had as most Royal Air Force aircraft a natural metal scheme with various metal shades. Some 12 mk.53 were acquired which was a F.6 derivative (with thus a larger wing with kinked leading edge and larger belly). The armaments were first the 30mm Aden cannons and Red Top or Firestreak missiles and the typical over wing fuel tanks.

Special unique mk.53/ F.53 features were for its ground attack capability: the unguided rocket carrying retractable doors aft of the nose gear bay, rocket pods on top of the wing (e.g. in stead of the overwing fuel tank) and Matra rocket pods on outboard wing pylons. Bombs could also be carried on outboard wing pylons.

From beginning 1969 all aircraft were flown from Kuwait City airfield until 1982.

(The Kuwait Air Force also used 2 Lightning trainers T.55).

DECAL SYSTEM

The decal sheet has one continuous print film, so each decal needs to be cut out with fine scissors.

No other prior decal preparation is needed.

Each cut out decal can be applied as usual after soaking it a short while in water. Decals are VERY THIN, so slide off from the wet backing sheet on a horizontally held GLOSSY model surface.

Note that a decal that contains a white section is often split in two parts. To get the full decal marking, apply both. On the decals sheet you will often see an "arrow" to indicate this way of application (on white under surfaces, the white section is optional).

After all decals have been applied, finish the model with your preferred final gloss, matt or semi-matt varnish coats. This will also protect all the decals.

KUWAIT DECALS SCHEMES

Four different numbers and codes are provided for Kuwait Lightnings.

Natural metal scheme with various metal shades. Many aircraft had a white background behind some of the stencillings, these are on the decal sheet as option to the kit decals. Studying photos is recommended, using books and internet.

It is unclear if the red-white striped panel striped decal on fuselage is applicable. Decal (marked B) was sometimes seen amidst the fuselage, often on a white panel.

Kuwait Lightnings had 2 large arabic numbers on the lower wing in front of each main gear bay that correspond with the numbers on the fuselage. Several arabic numbers are on the sheet to compose these.

Typical lower and upper markings:

Apply black walk way stripes as per kit. 2x5 black arabic texts for the walk ways (marked w) are provided although it is not clear if these were always applied.

The wing had 2x2 roundels.

DETAILS

Use stencilling and walk way stripes from the kit. On the sheet are a few stencillings with arabic texts. No details are known, photos may reveal these.

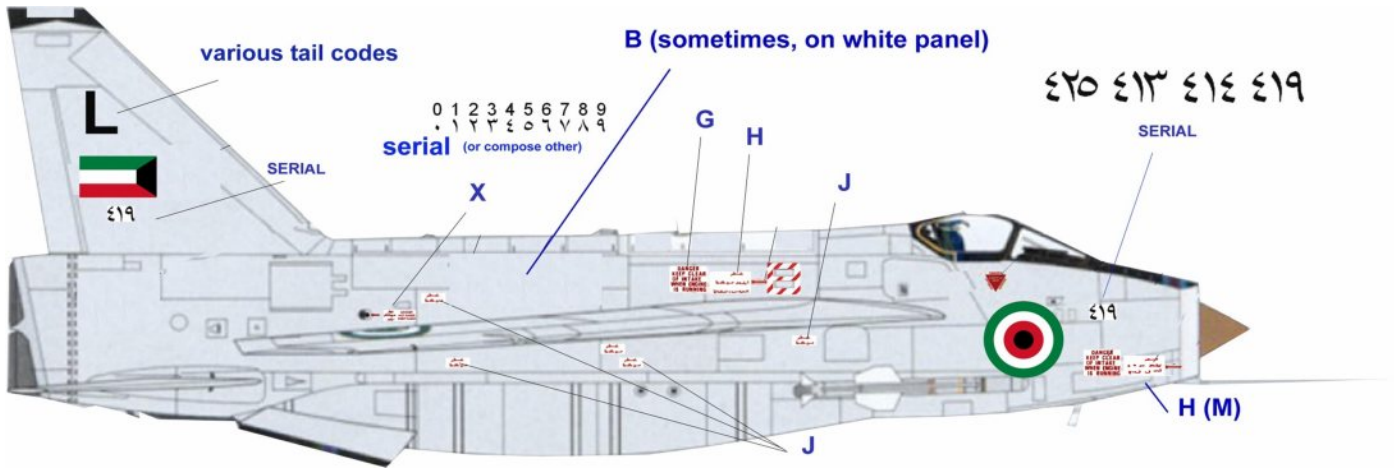

Kuwait Air Force, F.53, "419" with tail code "L"

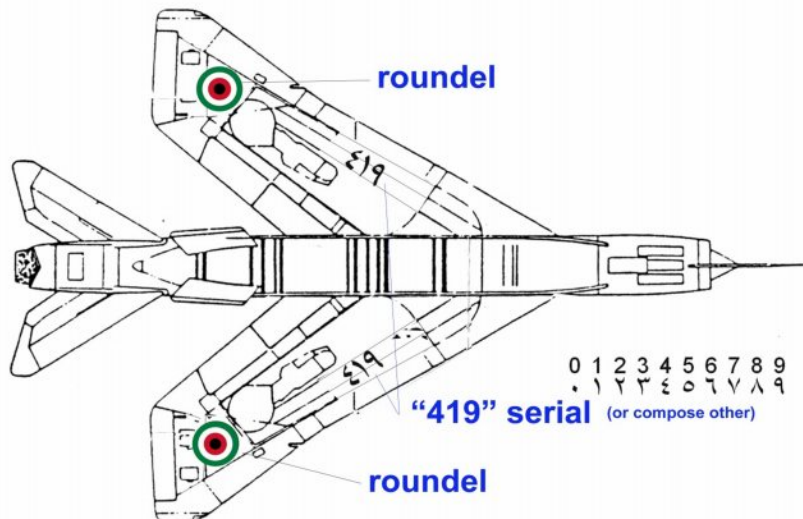
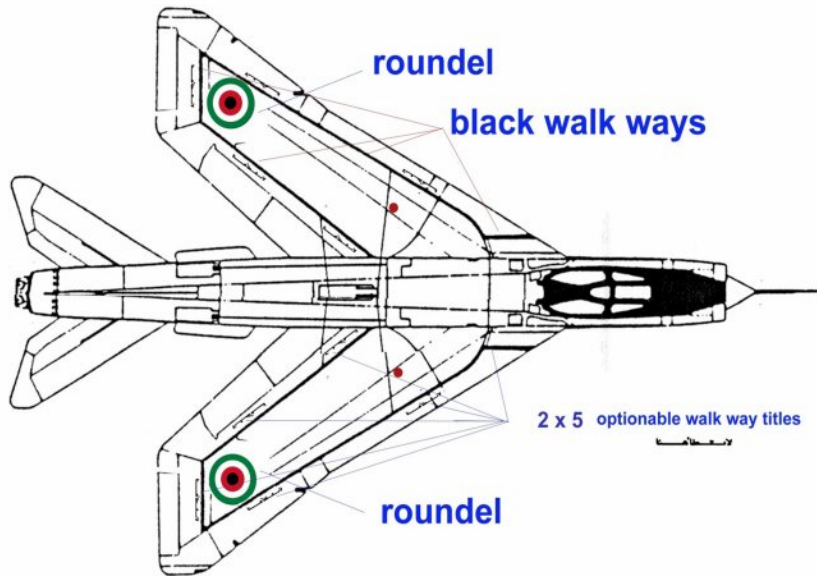

Please visit website: www.aircraftinplastic.com

